

# BULK MATERIAL HANDLING SOLUTIONS

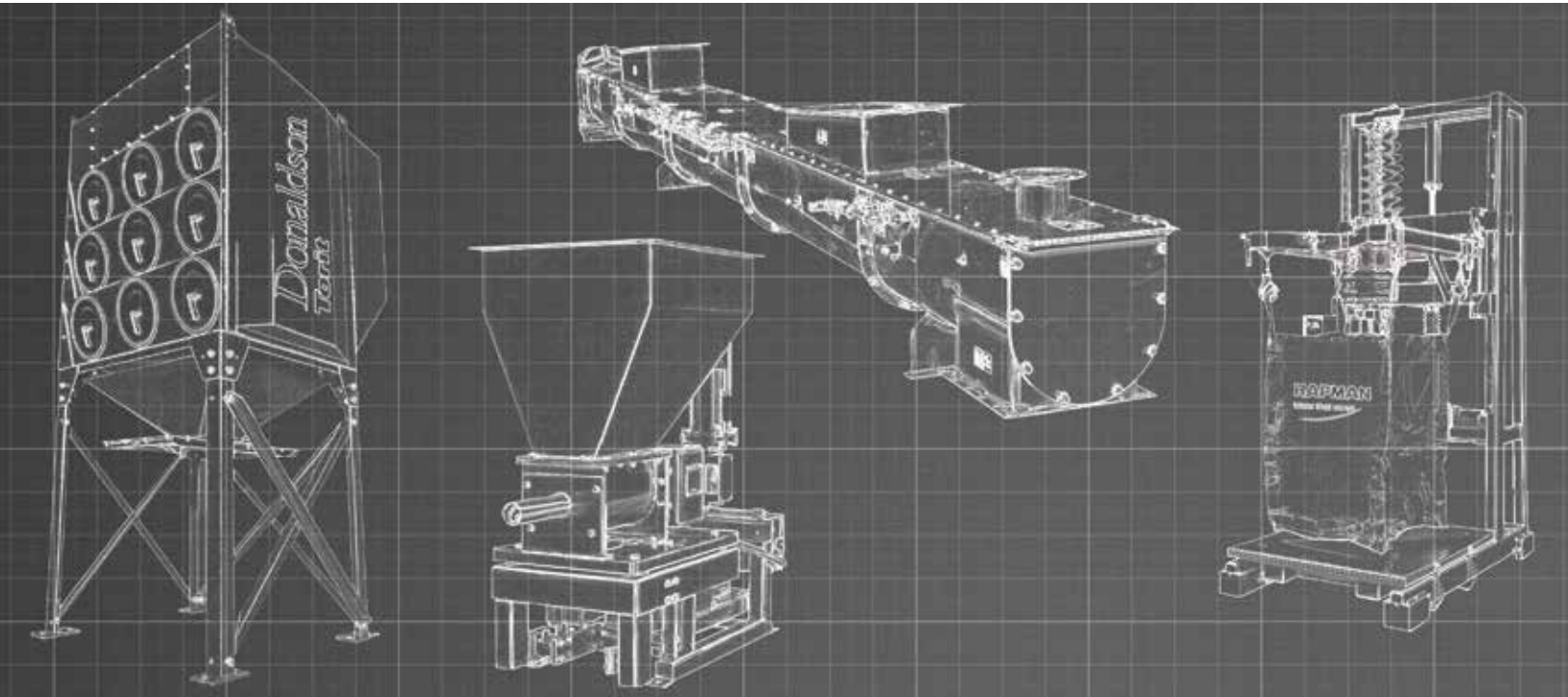

**PNEUMATIC & MECHANICAL CONVEYING**

**WEIGHING, FEEDING & LEVEL DETECTION**

**DUST COLLECTION, DUCTING & CYCLONES**

**EXPLOSION MITIGATION AND PREVENTION**

**BULK DISCHARGE, FILLING & TRANSLOADING**

**MAGNETIC SEPARATION & METAL DETECTION**

**SIZE REDUCTION, GRINDING & COMPACTION**

**AUTOMATED PACKING & ROBOTIC PALLETIZING**

**ROTARY VALVES, DIVERTER VALVES & DEDUSTERS**

**SCREENING, SIZERS, SORTING, FLUIDIZED BED SPRAY  
& DRUM DRYERS AND COOLERS**

## APPROTEC RAN-LE

Approtec Ran-Le provides solutions for customers located in Texas, Louisiana, Oklahoma, Arkansas and Southern Mississippi. For close to 50 years, we have been providing material handling solutions to a wide range of industries. Projects range from bulk bag discharging and batching, pneumatically conveying plastic pellets, metal detection on a food packaging line, to ultra high efficiency cyclones and wet scrubbers.



[approtec.com](http://approtec.com)

## Size Reduction

Fine Grinding and Milling Machines  
Lump Breakers & Hammermills  
Scalable Lab System™ (SLS)  
Industrial Powder Screening  
COMIL® Conical Mill

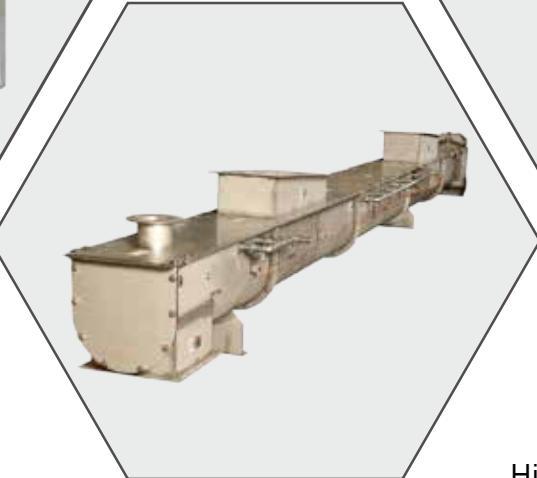

## Screening, Grading, Sorting, Cooling & Drying Technology

Round Vibratory Separators and Check-Screeners  
Fluidized Bed, Drum Dryers and Coolers  
Mogensen Sizers & Sorting Systems  
Gyratory Motion Screening



## Packaging and Palletizing

World's fastest continuous motion VFFS machine  
Ultra Sanitary intermittent motion VFFS  
Premade pouch & stick pack machines  
Robotic palletizing & case packing



## Material Handling Valves

Airlock/Double-Dump Valve Assemblies  
Medium & High Pressure Rotary Valves  
NFFPA-6g Rotary Airlock Feeders  
Clean-Flow Diverter Valves  
Pneumatic Samplers  
Diverter Valves

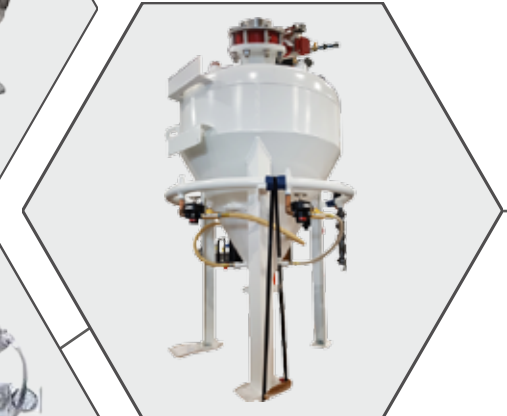

## Mechanical Conveying Systems

Tubular Drag Conveyors  
Aeromechanical Conveyors  
Flexible Screw Conveyors  
Belt & Chain Bucket Elevators  
Overland Conveying  
Conveyor Parts & Components

## Air Pollution Control and Fire & Explosion Safety

High Pressure & Temperature Dust Collection  
Dust Hazard Analysis & Site Audit Services  
Particulate Monitoring & Control Systems  
Wet Scrubbing & Packed Tower Systems  
Baghouse & Pulse Jet Dust Collectors  
Pollution Control / Product Recovery  
Full range of Passive, Flameless Venting,  
and Chemical Suppression Systems

Explosion Detection, Mitigation & Isolation Systems per NFPA

## Pneumatic Conveying Systems

Top or Horizontal Load Vacuum Filter Receiver  
Pneumatic Blending and Mixing Systems  
Convey & Loss in Weight Batch System  
Dense Phase Pneumatic Conveying  
Sanitary Vacuum Transfer Systems  
Housekeeping Vacuum Systems  
DeDuster® Systems

## Bagging, Filling, and Unloading

Bulk Bag Fillers with Cone Table Densification  
Volumetric & Gravimetric Feeders  
Bulk Bag Container Dischargers  
Truck & Railcar Loading Spouts  
Airslides & Mass Flow Feeders  
Bulk Bag Conditioners

1976

1994

2007

2010

2017



John Lewis founded  
Ran-Le & Associates

Gary Sealy founded  
Approtec Equipment Sales

Approtec acquires Ran-Le  
to form Approtec Ran-Le

Tony Kniffen & Brian Vandenberg  
purchase Approtec Ran-Le

Approtec Ran-Le acquires  
RK Wilson & Associates

# BULK MATERIAL HANDLING SOLUTIONS

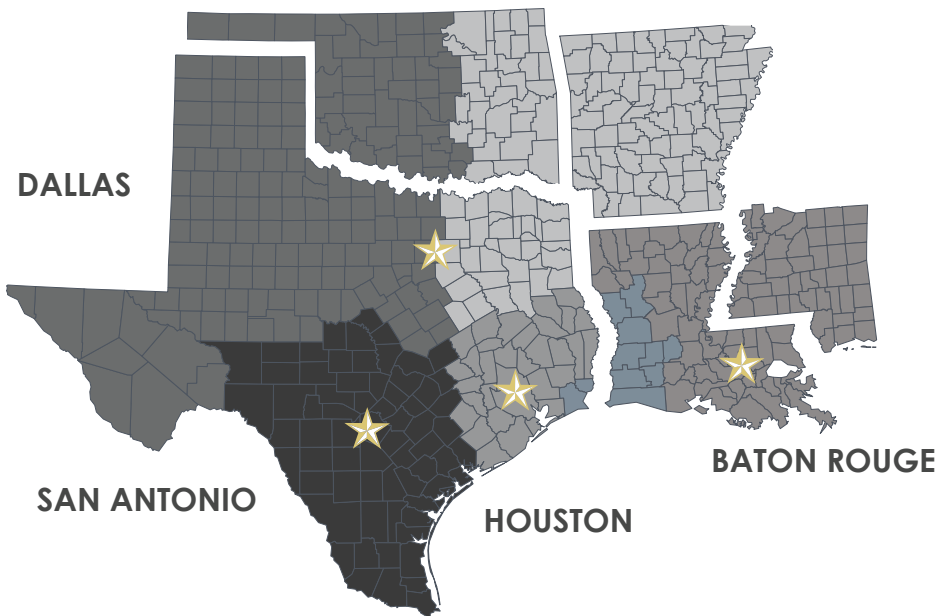
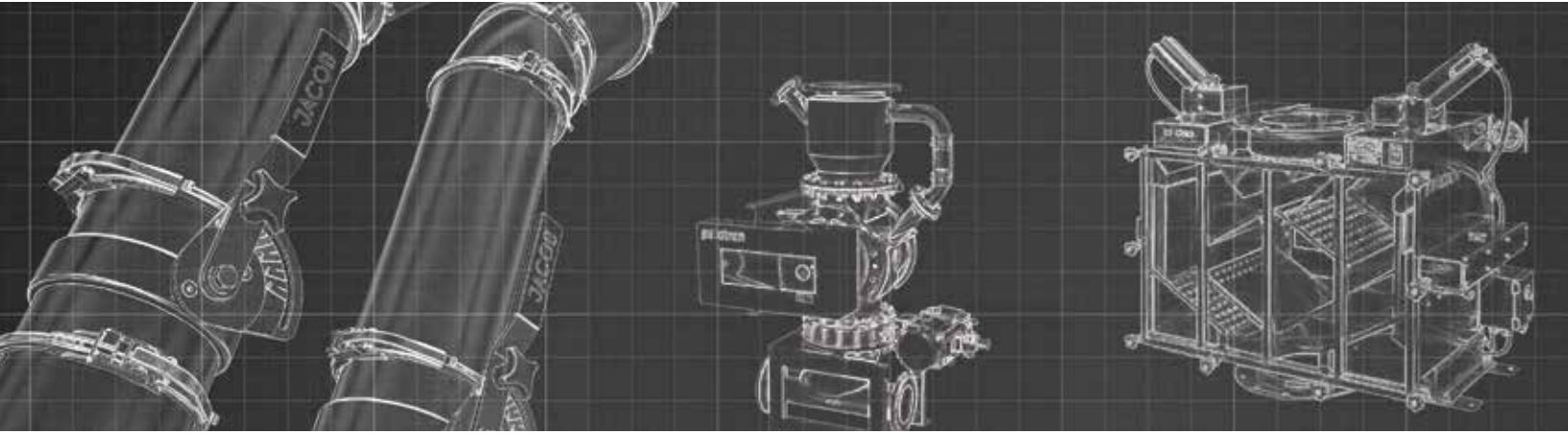

Proudly serving our customers since 1976. Supported by North American based manufacturing, our principals provide systems, components and replacement parts, and state-of-the-art test facilities.

[www.aprotec.com](http://www.aprotec.com)

## Get in touch

Call us at [\(281\) 350-0550](tel:2813500550) or send us an email at [info@aprotec.com](mailto:info@aprotec.com)



SAND



PLASTICS

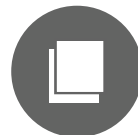

PULP & PAPER



WOOD PELLETS



AGGREGATES



CEMENT



FOOD



CHEMICALS